

TWO HANDLE KITCHEN FAUCET VALVE CARTRIDGE REPLACEMENT GUIDE

BEFORE YOU BEGIN YOUR INSTALLATION:

Traditional Model #s 8010-12, 8010-18, 8020, 8030



Turn off water supply.

REQUIRED TOOLS:



Phillips Screwdriver



Needle Nose Pliers



15mm Socket Wrench

1.

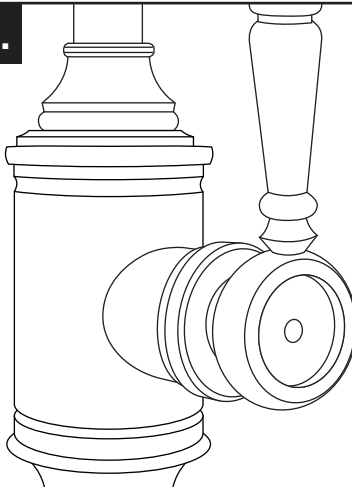

Locate notch at bottom of handle button (A). Pry off handle button with finger nail or small standard screwdriver. Remove handle retaining screw (B) and star washer (C).

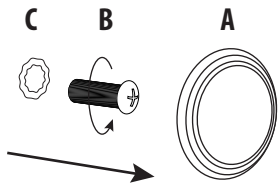

2.

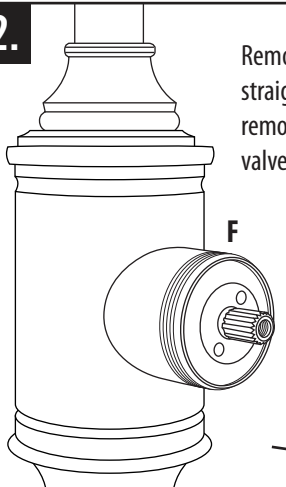

Remove handle (D) by pulling straight out. Unscrew and remove adjusting nut (E) from valve sleeve (F).

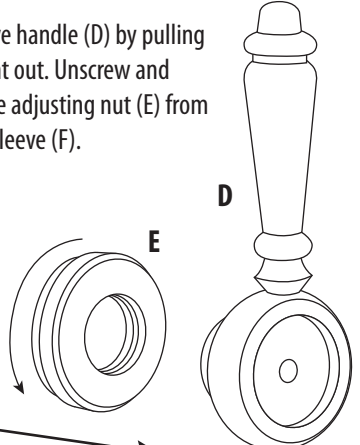

3.

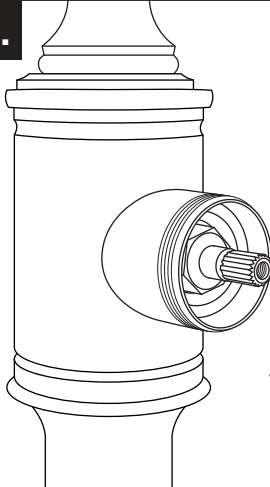

Remove pressure disk (G), brake pad (H1), brake disk (J), brake pad (H2), thrust washer (K) and wave spring (L).

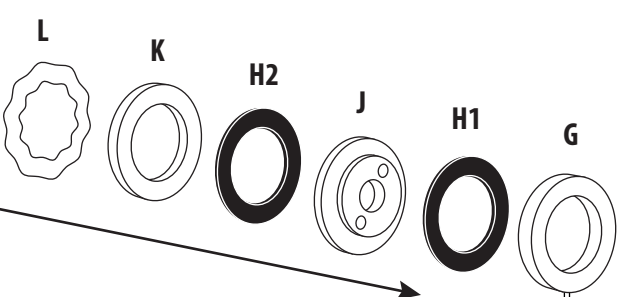

4.

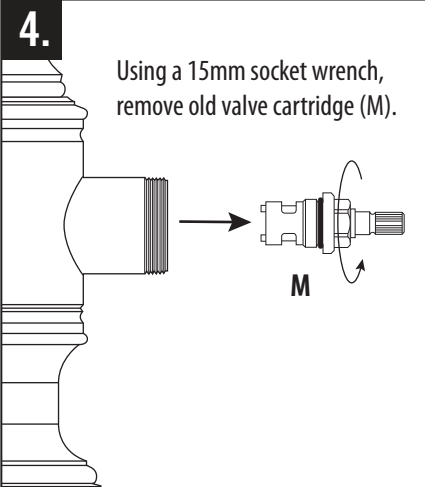

Using a 15mm socket wrench, remove old valve cartridge (M).

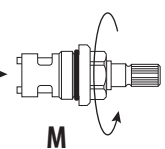

5.

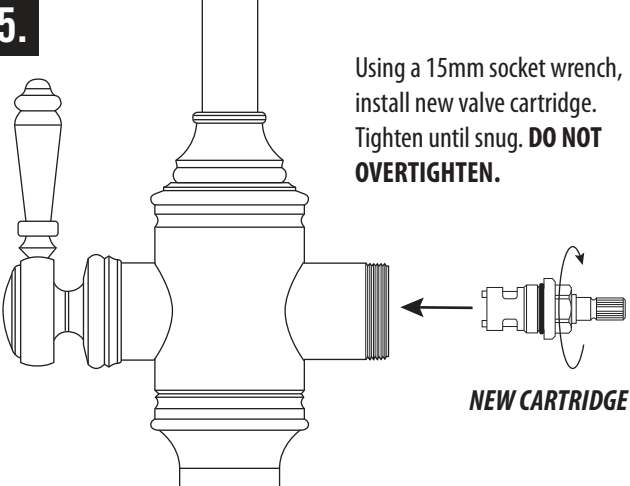

Using a 15mm socket wrench, install new valve cartridge. Tighten until snug. **DO NOT OVERTIGHTEN.**

NEW CARTRIDGE

6.

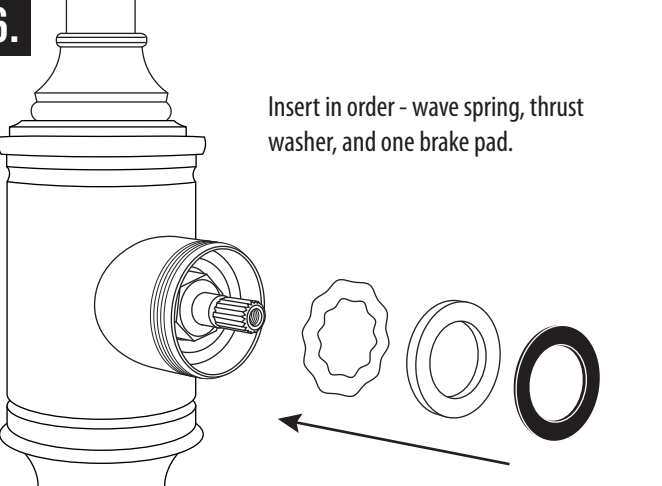

Insert in order - wave spring, thrust washer, and one brake pad.

